

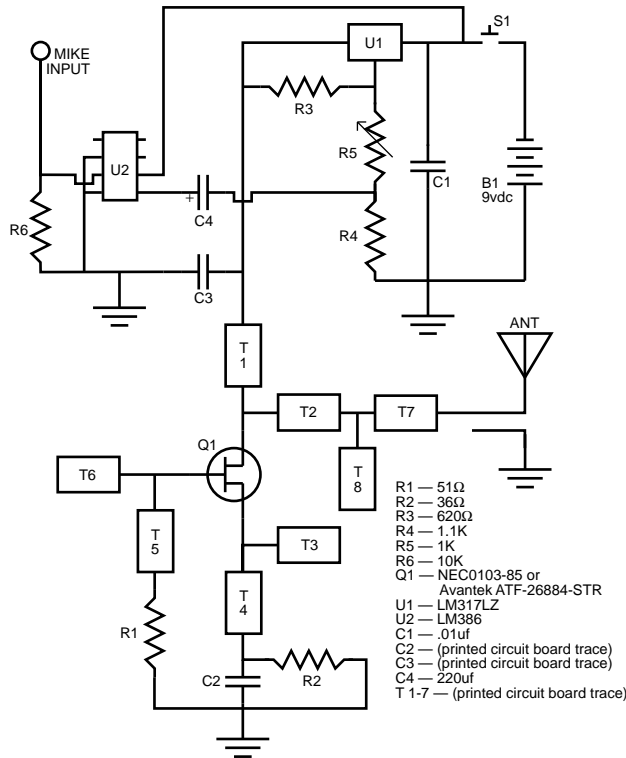

THE X-BAND BUG

C O U N T E R E S P I O N A G E C O N S U L T A N T S T O B U S I N E S S A N D G O V E R N M E N T



INVISIBLE TO MOST EAVESDROPPING DETECTION EQUIPMENT

A new electronic eavesdropping device has hit the open market — the X-Band Bug. This new wireless microphone transmits its signal in the 10 GHz frequency range (x-band) far beyond the receiving capabilities of normal radios and most professional countermeasures experts.

COSTS LESS THAN A GOOD MEAL

Until now, surveillance devices which use the microwave regions of the frequency spectrum were classified materiel owned only by government spy agencies. Recent advances in electronics have changed all this.

The components necessary for the electronic hobbyist to build microwave bugs are now cheap, and easily obtainable. In fact, the entire X-Band bug kit is only \$29.

A recent ad in a national magazine hyped this transmitter as being "Great for long-range testing of radar detectors — up to one mile." While this is true, an application note which is sold for an additional two dollars reveals the secret of adding voice to the transmitter's signal.

SPECIFICATIONS

Operating frequency: 10 - 11 GHz
 Power output: 10 mw
 Board size: 2" x .75" x .2"
 Cost: \$29 Kit / \$39 assembled + \$2 shipping
 Visa / MC / Check / MO / COD
 Availability: S tock
 Source: (check magazines for ads)

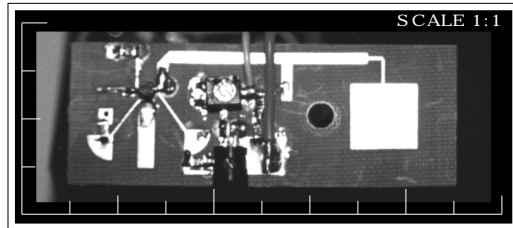

TEST RESULTS

Our tests confirmed this device is a legitimate threat. Realistic reception distances of up to two tenths of a mile (half a mile or more under ideal conditions) can be expected. Microwaves do not penetrate solid materials very well, but their signals can be directed like flashlight beams. These beams are very directional and reflect off solid objects well.

Note: Due to the seriousness of this technological advancement, we are openly sharing our findings with corporate countermeasures teams, colleagues and competitors alike so they can upgrade their spectrum analysis capabilities accordingly.

RECOMMENDATIONS

- Locate these bugs using a spectrum analyzer capable of receiving frequencies up to 40+ GHz.
- Do not rely on modified police radar detectors, or broad-band receivers for detection. They will not work.
- Carefully search around window and roof areas for microwave radiators and feed horns. Due to the thinness of these transmitters, also check carefully anything which faces a window: spines of books for example.
- The receiver for these devices will be found at a perpendicular angle to the front plane of these transmitters.
- Do not overlook the possibility of deliberate beam bounce to get the signal out of the area.

The almost undetectable X-Band Bug is only one spy trick. There are hundreds more. Remember — Espionage is preventable. For further information about pro-active programs to combat espionage, electronic eavesdropping and wiretapping please contact us.

908-832-7900
 www.spybusters.com
 Box 668, Oldwick, NJ 08858